

Automated Energy Efficiency for the Intelligent Business

Intel® Xeon® Processor 5500 Series Delivers Energy
Efficiency Without Compromising Performance



Energy demands in the data center are compromising business agility. In a recent survey, 42 percent of data center owners said they would exceed power capacity within the next 12-24 months, and 39 percent said they would exceed cooling capacity in the same timeframe.¹ And IDC estimates that for every dollar IT spends on hardware to support new users and applications, they spend another 50 cents on power and cooling for existing hardware.² As data centers reach the upper limits of their power and cooling capacity, efficiency has become the focus for data center design and extending the life of existing data centers.



Intel has helped reduce data center power consumption by delivering greater performance in the same power envelope for the past couple of years. The next challenge is to help data centers use energy more efficiently at all times, across all workloads. The Intel® Xeon® processor 5500^A series provides a foundation for IT management to refresh existing or design new data centers from the inside out to achieve greater performance while using less energy and space. Data center efficiency starts at the core – with energy-efficient processors and sub-systems to get the most out of each server rack, pedestal or blade. The CPU is the single largest consumer of power in servers today, so refreshing server infrastructure with highly efficient processors can deliver large gains. The Intel Xeon processor 5500 series with Intel® Intelligent Power Technology, delivers up to 50 percent lower idle power.³ By replacing aging single-core processor-based servers with new, more energy-efficient servers, you can gain capacity to grow and to increase IT performance using fewer servers. The estimated cost savings from energy and other operating cost efficiencies can pay for new servers in a an estimated 8 months.⁴

Automating Energy Efficiency

Energy should be spent when and where it provides business benefits. Intel® Microarchitecture, codenamed Nehalem, delivers performance on demand and conserves power through judicious use of the available resources. Within an individual server, Intel Intelligent Power Technology minimizes power consumption:⁵

Integrated Power Gates allow individual idling cores to be reduced to near-zero power independent of other operating cores (see Figure 1) reducing idle power consumption by up to 50 percent versus the previous generation of two-socket server processors.⁶

Automatic Operation or Manual Core Control

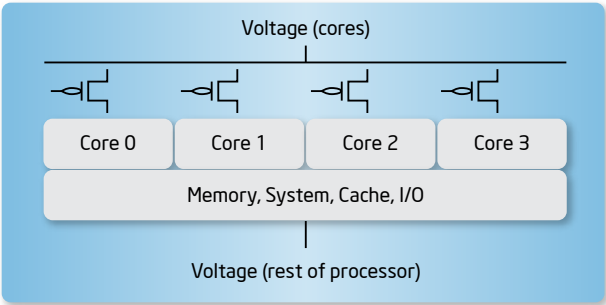
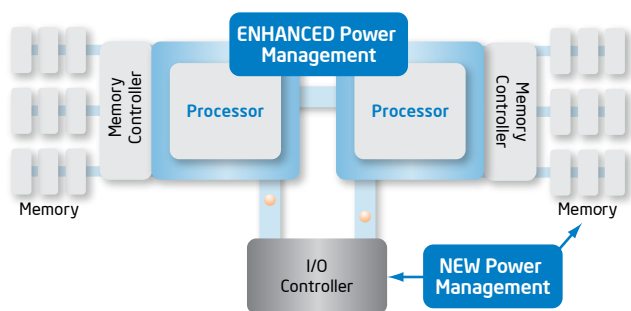

Figure 1. Integrated Power Gates enable idle cores to go to near-zero power independently.

Automated Low-Power States automatically put processor and memory into the lowest available power states that will meet requirements of the current workload while not impacting performance. The Intel Xeon processor 5500 series delivers a 5x improvement in power management capabilities from the first Intel quad-core processors: 5x as many operating states, a 5x reduction in idle power, and 5x faster transitions to and from low-power states.⁷



- More and lower CPU power states
- Reduced latency during transitions
- Power management now on memory, I/O

Figure 2. Automated Low-Power States adjust system power consumption based on real-time load.

Efficiency Yields Agility

Energy should enhance, not compromise, business efficiency. The Intel Xeon processor 5500 series demonstrates superior performance/watt across a wide range of workload performance requirements, delivering as much as 2.25x more performance in a similar power envelope.⁸ Superior energy efficiency gives you greater business agility, delivering more performance to speed existing applications and business processes or the capacity and compute headroom to add new ones.

Building Core Efficiency

Data center efficiency starts at the core – with energy-efficient processors and sub-systems to get the most out of each server. The CPU is the single largest consumer of power, so refreshing server infrastructure with highly efficient processors can deliver large gains. The Intel Xeon processor 5500 series with Intel Intelligent Power Technology, delivers the highest system-level performance/watt.⁹ By refreshing IT infrastructure with these energy-efficient systems, you can gain capacity to grow and to increase IT performance, and the estimated cost savings from energy alone can pay for new servers in a matter of months.¹⁰

Intelligent Power Management and Virtualization

Virtualization and energy efficiency go hand-in-hand, because it allows consolidation of workloads onto fewer physical platforms which saves on power, space, and cooling costs.

The Intel® Intelligent Power Node Manager and operating system tools allow IT managers to set a power budget for a rack, a row of servers, or the entire data center, enabling up to 20 percent denser deployments.¹¹

Better virtualization performance enables higher consolidation ratios. Enhancements to Intel® Virtualization Technology† (Intel® VT) in combination with a new platform design provide up to 2.1x higher virtualization performance versus last year's Intel two-processor servers.¹² New support for Intel® VT Extended Page Tables increases virtualization performance by reducing the overhead caused by page-table virtualization.

Flexible, real-time consolidation with Intel® VT FlexMigration and leading virtualization software solutions help IT to conserve power during non-peak periods by rebalancing workloads on fewer platforms to reduce energy costs. Workloads running in virtual machines (VMs) can either be transferred manually or through policy-based scripts to run on fewer servers.

Customers using Intel-based servers have achieved dramatic consolidation, enhanced business performance and reduced IT costs through virtualization. Read about their results at www.intel.com/references.

Learn More

Efficiency is emerging as a major tool to extend the life of existing data centers and ensure that new data centers will deliver the highest ROI. The Intel Xeon processor 5500 series with Intel Microarchitecture Nehalem empowers IT to maximize the business value of servers while shrinking energy costs.

For more information about the Intel Xeon processor 5500 series, visit www.intel.com/xeon.

For more information about Intel Microarchitecture Nehalem, visit www.intel.com/technology/architecture-silicon/next-gen.

For more information on the SPECpower benchmark, see www.spec.org/power_ssj2008.

For more information about data center TCO, read isdlibrary.intel-dispatch.com/isd/114/datacenterTCO_WP.pdf.

⁴ Intel processor numbers are not a measure of performance. Processor numbers differentiate features within each processor family, not across different processor families. See www.intel.com/products/processor_number for details.

¹ Intel® Virtualization Technology requires a computer system with an enabled Intel® processor, BIOS, virtual machine monitor (VMM) and, for some uses, certain platform software enabled for it. Functionality, performance or other benefits will vary depending on hardware and software configurations and may require a BIOS update. Software applications may not be compatible with all operating systems. Please check with your application vendor.

¹ Source: Infoworld, March 26, 2008.

² Source: IDC Document: Virtualization and Multicore Innovations Disrupt the Worldwide Server Market. Document number: 206035. Publish date: March 2007.

³ Intel internal measurements of 221W at idle with Supermicro 2xE5450 (3.0GHz 80W) processors, 8x2GB 667MHz FBDIMMs, 1x700W PSU, 1x320GB SATA hard drive vs. 111W at idle with Supermicro software development platform with 2xE5540 (2.53GHz Nehalem 80W) processors, 6x2GB DDR3-1066 RDIMMs, 1x800W PSU, 1x150GB 10k SATA hard drive. Both systems were running Windows 2008 with USB suspend select enabled and maximum power savings mode for PCIe link state power management. Measurements as of Feb 2009.

⁴ Source: Intel, March 2009. Compares replacing nine four year old single core Intel® Xeon® processor 3.8GHz with 2M cache based servers with one new Intel Xeon Processor X5570 based server. Results have been estimated based on internal Intel analysis and are provided for information purposes only.

⁵ Intel® Intelligent Power Technology requires a computer system with an enabled Intel® processor, chipset, BIOS and for some features, an operating system enabled for it. Functionality or other benefits may vary depending on hardware implementation and may require a BIOS and/or operating system update. Please check with your system vendor for details.

⁶ Intel internal measurements of 221W at idle with Supermicro 2xE5450 (3.0GHz 80W) processors, 8x2GB 667MHz FBDIMMs, 1x700W PSU, 1x320GB SATA hard drive vs. 111W at idle with Supermicro software development platform with 2xE5540 (2.53GHz Nehalem 80W) processors, 6x2GB DDR3-1066 RDIMMs, 1x800W PSU, 1x150GB 10k SATA hard drive. Both systems were running Windows 2008 with USB suspend select enabled and maximum power savings mode for PCIe link state power management. Measurements as of Feb 2009.

⁷ Xeon® 5300 series data based on Xeon® X5365 SKU (B-3 stepping), Xeon® 5400 series based on Xeon® X5470 (E-0 stepping), and Xeon® 5500 based on Xeon® W5580 (D-0 stepping). Number of operating states includes all frequency operating points, including Turbo Boost and base frequency. Idle power based on C6 idle power for Xeon® 5500, and C1E for Xeon® 5300 and 5400 SKUs. C6 also requires OS support and may vary by SKU. Faster transitions based on Package C1E exit transition latency.

⁸ Compared to Xeon 5400 series. Claim supported by multiple performance results including an OLTP database benchmark and a bandwidth intensive scientific computing benchmark (SPECfp_rate_base2006). Intel internal measurement. (Feb 2009).

⁹ Intel internal measurements of 221W at idle with Supermicro 2xE5450 (3.0GHz 80W) processors, 8x2GB 667MHz FBDIMMs, 1x700W PSU, 1x320GB SATA hard drive vs. 111W at idle with Supermicro software development platform with 2xE5540 (2.53GHz Nehalem 80W) processors, 6x2GB DDR3-1066 RDIMMs, 1x800W PSU, 1x150GB 10k SATA hard drive. Both systems were running Windows 2008 with USB suspend select enabled and maximum power savings mode for PCIe link state power management. Measurements as of Feb 2009.

¹⁰ Source: Intel, March 2009. Compares replacing nine four year old single core Intel® Xeon® processor 3.8GHz with 2M cache based servers with one new Intel Xeon Processor X5570 based server. Results have been estimated based on internal Intel analysis and are provided for information purposes only.

¹¹ Source: Dynamic Power Optimization for Higher Server Density Racks – A Baidu Case Study with Intel® Dynamic Power Technology (Intel, 2008). See <http://communities.intel.com/servlet/JiveServlet/previewBody/1492-102-1-1723/Node%20Manager%20Baidu%20POC%20WhitePaper%20-%20External.pdf> for more details.

¹² Performance results on VMmark benchmark. Xeon X5470 data based on published results. Xeon X5570 Intel internal measurement. (Feb 2009): HP ProLiant ML370 G5 server platform with Intel Xeon processors X5470 3.33GHz, 2x6MB L2 cache, 1333MHz FSB, 48GB memory, VMware ESX V3.5.0 Update 3 Published at 9.15@ 7 tiles vs Intel® Xeon® processor X5570, 2.93 GHz, 8MB L3 cache, 6.4QPI, 72GB memory (18x4GB DDR3-800), VMware ESX Build 140815. Performance measured at 19.51@ 13 tiles.

Performance tests and ratings are measured using specific computer systems and/or components and reflect the approximate performance of Intel products as measured by those tests. Any difference in system hardware or software design or configuration may affect actual performance. Buyers should consult other sources of information to evaluate the performance of systems or components they are considering purchasing. For more information on performance tests and on the performance of Intel products, visit <http://www.intel.com/performance/resources/> or call (U.S.) 1-800-628-8686 or 1-916-356-3104.

This information is preliminary and subject to change. For more information, please visit www.intel.com/performance.

Copyright © 2009 Intel Corporation. All rights reserved. Intel, the Intel logo, and Intel Xeon are trademarks of Intel Corporation in the United States and other countries.

*Other names and brands may be claimed as the property of others.

